



# CUSTOMER



# Europanel srl

**ORDER** N° ..... **OFFER** N° .....

N° ..... PREWIRED SHAFT LINES  PUSH BUTTON INCLUDED TRADE MARK ..... MODEL .....

**TRACTION LIFT**  PUSH BUTTON ON TOLLING TRADE MARK ..... MODEL .....

Machine Room  ON TOP  BELOW  ONLY PREWIRED LINES - PUSH BUTTON NOT INCLUDED

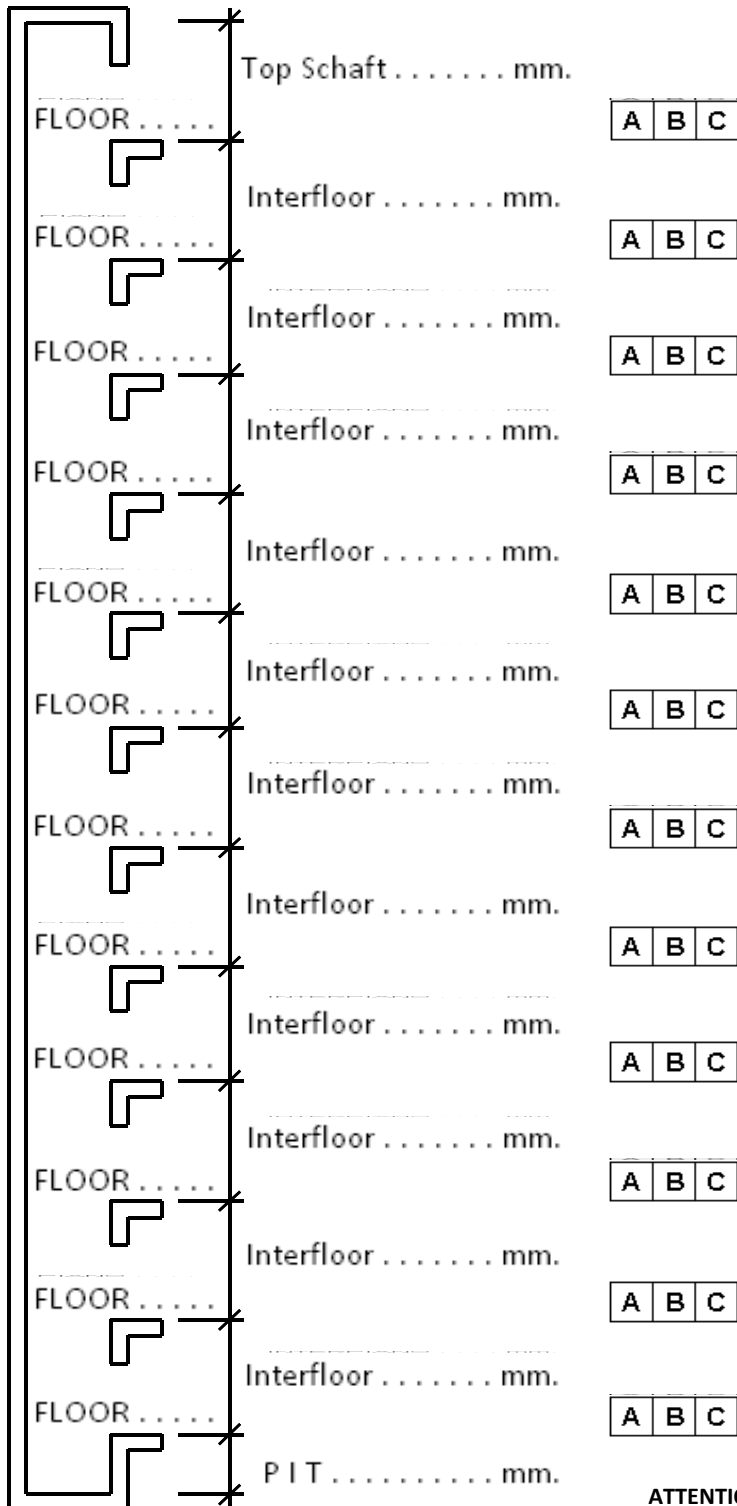

DISTANCE FROM MACHINE ROOM AND SHAFT  
mm. ....

- DM 236 L13 LIGHT AT FLOOR .....
- DM 236 L13 LIGHT AT ALL FLOOR
- .....
- .....

**ACCESSORIES**

- BIDIRECTIONAL KIT  
( CABLES AND CONNECTION INCLUDED )
- QUADRO GENERALI FM. .... A. + LUCE
- SHAFT LIGHTING
- TRADITIONAL MACHINE ROOM LIGHTING KIT
- M. ROOM LIGHTING KIT ON CONTROLLER
- .....
- .....
- .....

**OTHER**

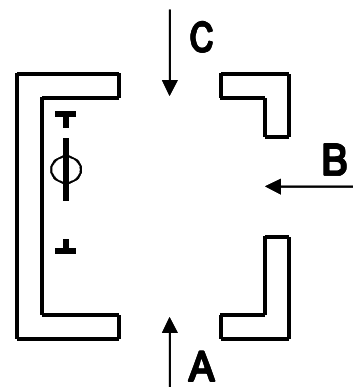

**ATTENTION ALL MEASURES / QUOTES MUST BE IN MILLIMETERS**

NOTE: