

CUSTOMER



Europanel srl

ORDER N°

OFFER N°

N°..... PREWIRED SHAFT LINES

PUSH BUTTON INCLUDED

TRADE MARK..... MODEL.....

HYDRAULIC LIFT

PUSH BUTTON ON TOLLING

TRADE MARK..... MODEL.....

Machine Room

ON TOP

BELOW

ONLY PREWIRED LINES - PUSH BUTTON NOT INCLUDED

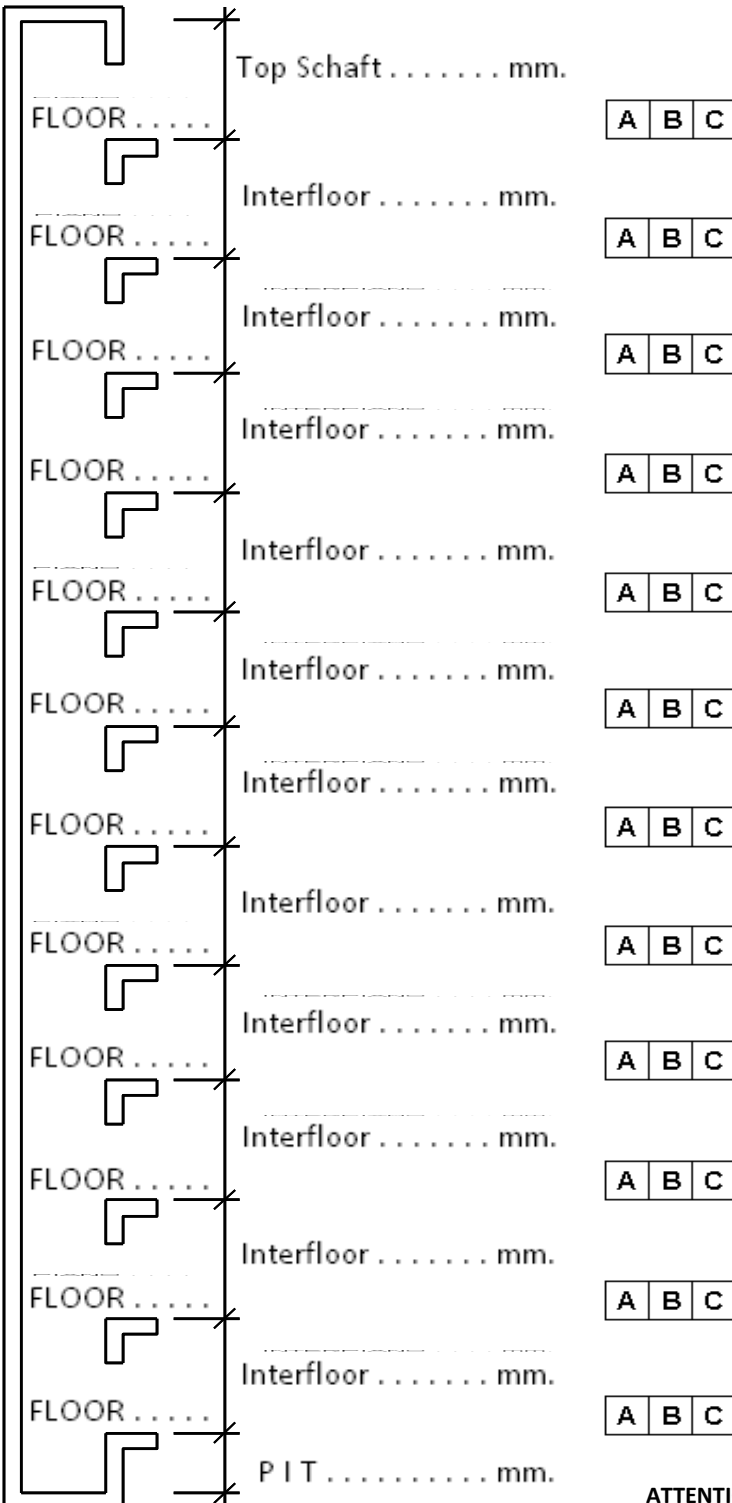

DISTANCE FROM MACHINE ROOM AND SHAFT
mm.

DM 236 L13 LIGHT AT FLOOR.....

DM 236 L13 LIGHT AT ALL FLOOR

.....

.....

ACCESSORIES

BIDIRECTIONAL KIT

(CABLES AND CONNECTION INCLUDED)

CAR TELEPHONE

2-WAY COMMUNICATION

SWITCH PANEL FM..... A. + LIGHT

SHAFT LIGHTING

TRADITIONAL MACHINE ROOM LIGHTING KIT

M. ROOM LIGHTING KIT ON CONTROLLER

.....

.....

.....

OTHER

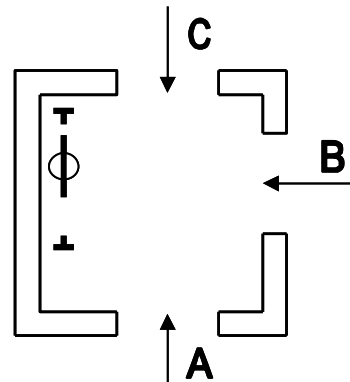

ATTENTION ALL MEASURES / QUOTES MUST BE IN MILLIMETERS

NOTE: